

REFU Power Quality REFULOG – Monitoring Portal

Operating instructions DOK-RESOL-BA01-EN-REFULOG-NN-P.doc

The screenshot displays the REFULOG monitoring portal for the 'Anlage REFU Metzingen / Neuhausen'. The interface includes a navigation menu, system overview, detailed system data, current data, and a power output graph.

System Overview:

- Anlagenübersicht:** REFU Metzingen / Neuhausen (211, 212, 213, 214)
- Anlage 'REFU Metzingen / Neuhausen':**
 - Anlagendaten:**
 - Beschreibung: Dies ist die Testanlage der REFU Elektronik GmbH
 - Eigentümer: REFU Elektronik GmbH
 - Installierte Leistung: 47,0 kWp
 - Modultyp: 72 Module SF200A-223, 108 Module SF130/4-135 Solar-Fabrik
 - Ausrichtung: -8 °
 - Neigung: 19,0 °
 - Modulfläche: 0,0 m²
 - Wechselrichter: 4
 - Wechselrichtertypen: 800R015 (4)
 - Einspeisetarif: 0,48 €
 - Aktuelle Daten:**
 - Status:
 - Ertrag: 65 €
 - Gesamtertrag: 135 kWh
 - CO₂ Einsparung: 74 kg
 - Aktuelle Leistung: 3.465,2 W
 - Tagesertrag: 3,7 kWh
 - Tagesertrag normiert: 6,08 Wh/Wp
 - Einstrahlung: 29 W/m²
 - Modultemperatur: -1 °C
 - Letzter Datenempfang: 20.02.2019 11:00:00

Statistik:

The graph shows AC power output (AC Leistung) in Watts (W) over time for 30.12.2008. The y-axis ranges from 0 kW to 16 kW, and the x-axis shows hours from 6:00 to 21:00. The power output peaks at approximately 14 kW around 12:00.

Datenauswahl:

- REFU Metzingen / Neuhausen
- 211
- 212
- 213
- 214

Buttons: << Hinzufügen

Fehlermeldungen:

1 REFU Metzingen / Neuhausen AC Leistung W

Page Footer:

REFU Elektronik © Copyright 2008 REFULOG verbessern Über REFULOG | Nutzungsvereinbarung | Datenschutz

Title bar	REFU Power Quality REFULOG® – Monitoring Portal REFULOG® is a registered trademark of REFU Elektronik GmbH
Documentation type	Operating instructions
Documentation purpose	This documentation describes how to connect a photovoltaic plant featuring REFUSOL inverters to the REFULOG monitoring portal. It provides information <ul style="list-style-type: none"> • on the connection of the REFUSOL inverter to the router required, and • on the configuration of the photovoltaic plant in the REFULOG monitoring portal. This description takes effect in 08. 2009.

Revisions

Version code	Version	Remarks
DOK-RESOL-BA01-EN-REFULOG-NN-P	02.2010	Setting with Firewall 1.3.2

Copyright	© REFU Elektronik, 27. Mai 2010. Copying this document and transfer thereof to third parties, as well as exploitation and communication of its contents, are not permitted without explicit prior consent. Failure to comply will lead to claims for liability. All rights are reserved in the event of the grant of a patent or the registration of a utility model or design (DIN 34-1).
Obligation	The data specified is for product description purposes only and may not be deemed to be guaranteed in a legal sense. We reserve the right to modify the contents of the documentation and supplies of the products.
Editor	REFU Elektronik GmbH Marktstr. 185 • D-72793 Pfullingen Phone +49 (0) 7121.4332-102 • Fax +49 (0) 7121.4332-140 http://www.refu-elektronik.de
Internal file reference	N:\VERTRIEB\VID\002 REFUSOL\300 Dokumentation\REFULOG\DOK-RESOL-BA01-EN-REFULOG-NN-P.doc

Table of Contents

1. Description of REFULOG®	4
2. The REFULOG®Monitoring Portal	5
3. Brief Startup Instructions	5
3.1 Hardware Installation	5
3.2 Configuring the network.....	6
3.3 Registering with REFULOG®	8
3.4 Configuring the plant under REFULOG®	8
4. Notes	9
5. Contact	10

1. Description of REFULOG®

- REFU Elektronik GmbH does not assume any liability for damage caused by failure to observe the warnings given in these operating instructions.
- The operating and maintenance instructions as well as safety-related guidelines must be read before commissioning.
- The terms of use and privacy terms referring to REFULOG® are applicable, which can be found under www.refulog.de.
- Proper and correct transport, storage, assembly and installation, as well as care in operation and maintenance, are prerequisites for optimal and safe operation of the device.
- Only assign trained and qualified personnel to work with electrical installations. Only persons who are trained and qualified for the use and operation of this device may work on or near the device. Such persons are qualified if they have sufficient knowledge of the assembly, installation and operation of the product, as well as an understanding of all warnings and precautionary measures contained in these operating instructions. Furthermore, such persons must be trained, instructed or authorized to switch electric circuits and devices on and off in accordance with technical safety regulations, to ground such circuits and devices and to identify them appropriately according to the requirements of safe work practices. These persons must also have adequate safety equipment and be trained in first aid.
- Only use spare parts and accessories approved by the manufacturer.
- Follow all safety regulations and requirements for the specific application as practiced in the country of use.
- The ambient conditions given in the product documentation must be observed.
- You may commission the device only after having verified that the machine or installation in which the products are installed complies with the national regulations, safety specifications and standards of the application.
- Operation is only permitted if the national EMC regulations for the application are met.
- The machine or installation manufacturer is responsible for compliance with the limit values as prescribed in the national regulations.
European countries: EC Directive 2004/108/EC (EMC Directive).
- Technical data as well as connection and installation conditions are specified in the product documentation and must be followed at all times.

2. The **REFULOG**[®]Monitoring Portal

Since any operator focuses his attention on the yield of his photovoltaic plant, he is mainly interested in ensuring and monitoring the functional performance of the plant.

In order to support you in your check of the economic efficiency and safety of your plant, we have established our internet-based monitoring portal REFULOG[®] BASIC. This portal allows you to make comprehensive evaluations and comparisons, for example, comparisons with statistical yield capacity values and/or with insolation and temperature sensors placed in the field.

Wherever you have access to the internet, you just have to enter your login data to quickly and easily monitor your photovoltaic plant.

REFULOG[®] offers the following advantages:

- Configuration of plants and partial plants: easy connection of the inverters through a unique activation code, location data, plant-specific data, photo of the plant
- Display of current parameters for each plant and each inverter: overall yields, day yields (absolute and standardized), AC/DC output (absolute and standardized), AC/DC voltage, AC/DC current, AC frequency, device temperature, insolation values, module temperature
- Display of the plants and inverters in clearly arranged lists for easy comparison
- Graphical evaluation of historic data (day, month, year and overall views, display of all plant and inverter parameters, combination of several channels in one diagram by means of a configurable statistics display)
- User management
- Overview of plant locations on an interactive map
- Multilingual application with appropriately localized presentation of numerical values and date formats
- No additional data logger required
- Intelligent plant monitoring through complex evaluation functions

3. Brief Startup Instructions

The following brief instructions provide a description of how to install the hardware and how to integrate a photovoltaic plant in the REFULOG[®].

3.1 Hardware Installation

Since the REFUSOL inverters transmit their data to the REFULOG[®] monitoring portal over an internet connection, all REFUSOL[®] inverters must be users in a local TCP/IP network. To achieve this, all REFUSOL inverters must be connected to the local router over their Ethernet interface. The local router will then establish the connection to the internet.

You can do this using intermediate steps over several switches or directly, depending on the number of REFUSOL[®] inverters connected in the network.

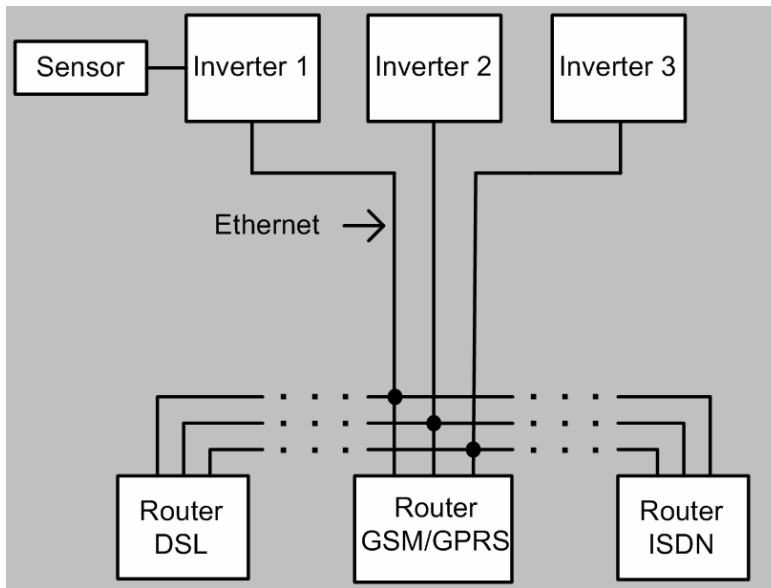

Fig.: 1 Examples of connecting 3 REFUSOL[®] inverters to the REFULOG[®] monitoring portal in a network

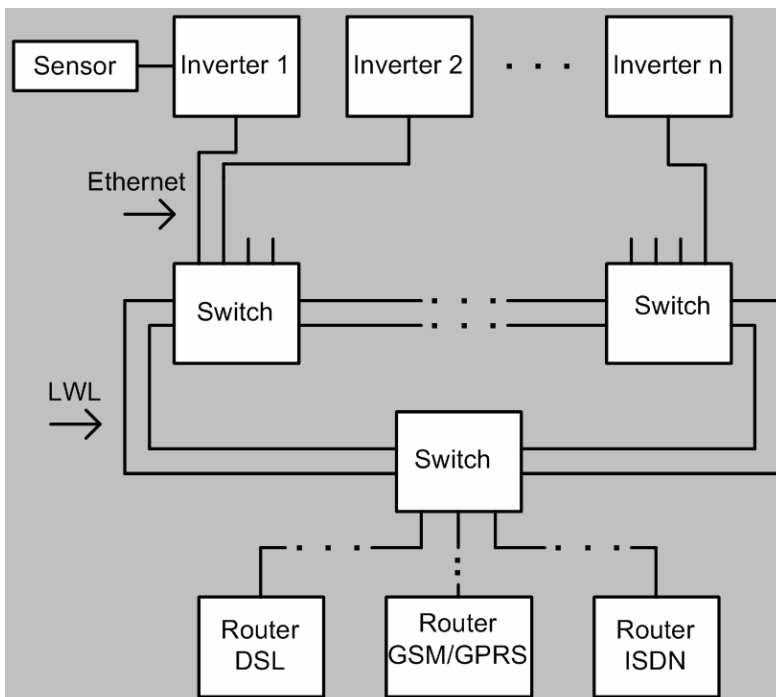

Fig.: 2 Examples of connecting several REFUSOL[®] inverters to the REFULOG[®] monitoring portal in a network

3.2 Configuring the network

In a TCP/IP network it is always the router that defines the IP settings of the network users. For this reason, the IP settings of the REFUSOL[®] inverters must be adjusted to those of the router.

Connect a laptop/PC to the router over an Ethernet line to find out the IP settings of the router. Enter the command "cmd" in the prompt line of your laptop/PC. Then enter "ipconfig" in the input window that appears. This input window will then display the IP settings of your laptop/PC.

```

Microsoft Windows XP [Version 5.1.2600]
(C) Copyright 1985-2001 Microsoft Corp.

P:\>ipconfig

Windows IP configuration

LAN connection Ethernet adapter:

Connection-specific DNS suffix: xxxx.int

    IP address.....: 192.168.100.10
    Subnet mask.....: 255.255.255.0
    Standard gateway.....: 192.168.100.1

P:\>

```

Fig.: 3 Enter "ipconfig" to call the IP settings after the prompt

The address of the standard gateway (IP address of the router) must be used as standard gateway for the REFUSOL[®] inverter as it is. Enter this address in parameters P414,0 – P414,3.

The subnet mask must also be applied to the REFUSOL inverter as it is. Enter the subnet mask in parameters P411,0 – P411,3.

The potential IP addresses of the REFUSOL[®] inverter are defined by the IP address of the router and the subnet mask. Example:

Router

IP address: 192.168.100.1

Subnet mask: 255.255.255.0

REFUSOL[®]

IP address: 192.168.100.xxx (2-254)

Subnet mask: 255.255.255.0

Standard gateway: 192.168.100.1

The 0 in the last block of the subnet mask indicates that there are still 253 IP addresses which can be selected as desired. The three preceding 255 blocks of the subnet mask indicate that the first three blocks of the IP address cannot be changed. They correspond to the first three blocks of the IP address of the router. You can select the IP address of the REFUSOL inverter according to the example above. Enter the IP address of the REFUSOL inverter in parameters P410,0 – P410,3.

Interrupt the DC voltage supply for approx. 10 seconds (DC switch) to ensure that the REFUSOL[®] inverter can apply the IP settings.

You can now check the network configuration of the REFUSOL[®] inverter using a conventional laptop/PC. To achieve this, connect the laptop/PC to the network instead of the REFUSOL[®] inverter using the latter's Ethernet cable and make the IP settings of the REFUSOL[®] inverter on this laptop/PC. After having opened the appropriate website (e.g., <http://www.refulog.de>), you can now verify whether the network is connected to the internet. If not and the website is not displayed, the-

re is an error in the network configuration (router or modem). If the website is displayed, the network is properly connected to the network. Connect the REFUSOL inverter to the network and check whether data is transferred from the REFUSOL inverter to the REFULOG monitoring portal. If no data is transferred, there is an error in the inverter (correct IP configuration, reboot after IP configuration?).

If communication of the REFUSOL[®] inverter to the web server is ensured, you can activate the portal function in the inverter. To achieve this, just set parameter 473,0 to 1. This will cause the REFUSOL[®] inverter to transmit its data to the REFULOG[®] monitoring portal at 10-minute intervals.

If the router uses a firewall, an exception rule must be created for this type of connection.

The REFUSOL[®] inverter uses a TCP/IP request to transmit data to server address 88.79.234.30, port 80.

3.3 Registering with REFULOG[®]

You can register before or after you have commissioned the photovoltaic plant. The data already transmitted by the REFUSOL[®] inverter will not get lost.

Go to the "www.refulog.de", click on the "Register" button and enter the data required.



Fig.: 4"Register" button

You will receive a validation e-mail from the REFULOG[®] server shortly thereafter. Confirm the validation link to ensure the authenticity of your e-mail address. The e-mail also contains your login data which you have to enter under www.refulog.de. You can change the generated password under user settings.



Fig.: 5"Login" button

3.4 Configuring the plant under REFULOG[®]

After you have logged in with REFULOG[®], the "Add plant" page will be opened. Ensure that you enter the plant data completely and correctly in order to prevent some of the monitoring functions from providing wrong values.

Once the photovoltaic plant is configured correctly, you can add the individual inverters to the plant ("+" inverter" menu item on the plant page). Enter the activation code of the particular inverter and the generator output connected to this particular inverter. You can also assign a name to the inverter.

Note: You will receive the activation code after having ordered the REFULOG[®] monitoring portal from REFU Elektronik GmbH.

Any data that might have been transmitted before that point will be applied to the REFULOG[®] monitoring portal after correct configuration of the photovoltaic plant and the REFUSOL[®] inverters.

4. Notes

5. Contact

Please address any questions on the configuration of your REFUSOL to:

REFU Elektronik GmbH

Marktstr. 185

D-72793 Pfullingen, Germany

Phone: +49 (0) 7121.4332-102

Fax: +49 (0) 7121.4332-140

Refusol@refu-elektronik.de

www.refu-elektronik.de

Please address any questions on failures or technical problems to:

Service hotline: +49 (0)7123 / 969 – 202 (from 8:00 a.m. to 5:00 p.m. on workdays)

Fax: +49 (0)7123 / 969 – 220

Email: service@refu-elektronik.de

REFU
Elektronik

REFU Elektronik GmbH

Marktstr. 185

D-72793 Pfullingen

Phone: +49 (0) 7121.4332-102

Fax: +49 (0) 7121.4332-140

mail@refu-elektronik.de

www.refu-elektronik.de

Part no: 00xxxxx